

Reduction of Oxygen Level Due To Over Stimulation Using Muscle Oximeter

GHOSH A

Biomedical Engineering Department
Amity University
Gurgaon

BEWAL R

Biomedical Engineering Department
Amity University
Gurgaon

HANDA Y

Assistant Professor & Head of Department
Biomedical Engineering,
Amity School of Engineering & Technology
Amity University
Gurgaon

Abstract: This project is based on the stimulation provided to the muscles and the alteration in the oxygen level due to its continuous usage. The main concept behind the development of this project was the misconception among people that the continuous usage of electronic stimulators to the muscles will enhance the performance of muscles but in contrast to this it actually weakens the strength of the muscles by decreasing the oxygen level of the muscles. This kit will eventually help in checking the oxygen level in the blood before and after the stimulation. In this project we are combining the concept of both electronic muscle stimulator and pulse oximeter. With the help of this device the patient will be able to the oxygen saturation his body before and after the stimulation. This device will be very useful for athletes and adult patients. With prolonged stimulation the muscles might get damaged because of the decrease in oxygen level.

Keywords: Oximeter; Stimulation; Oxygen level; Muscle; Degeneration; Strength

I. INTRODUCTION

In this project we are combining the concept of both electronic muscle stimulator and pulse oximeter. With the help of this device the patient will be able to know the oxygen saturation level his body before and after the stimulation. This device will be very useful for athletes and adult patients. With prolonged stimulation the muscles might get damaged because of the decrease in oxygen level. Muscle stimulators are widely used in today's life because everyone has become fitness concerned and regular workout to be fit by trying to enhance their muscles. With frequent loading they injure their muscles and this result in the usage of muscle stimulators for instant relief. The muscle stimulators available in the market contain pads which when placed on the affected area produces vibrations which stimulate the muscles present there. Our device contains pulse oximeter circuit which will help in knowing the oxygen level of blood The EMS comprises different choices of parameters to use its in several areas: sports, therapeutic, medical, [1], [2], [3], [4]. The acquired signal from the stimulated muscles allows us to provide information that can be used by a doctor to provide diagnosis or the most appropriate response [5].

This device will help such individuals to know the time duration for which they should use this stimulation. It will help in knowing them that for how much duration the stimulation will be beneficial and after what duration it will harm their muscles. People

have a misconception that if they have a muscle spasm or any other muscle related problem due to over stretching or weight training, they should use these muscle stimulators to recover from these. But they are not aware about the fact that such stimulations may also harm their muscles if used continuously after a particular time period. The vibrations which are send through these muscle stimulators will however reduce the pain and eventually make you feel relaxed but in the long run it will reduce the oxygen level of the blood which is served to the muscles. This decrease in the oxygen level will affect the functioning of the muscles in the long run. The property that allows the pulse oximeter to measure the oxygen saturation of hemoglobin is that blood changes color as hemoglobin absorbs varying amounts of light depending on its saturation with oxygen Pulse oximetry is a noninvasive method that enables rapid measurement of the oxygen saturation of hemoglobin in arterial blood. [6] It can rapidly detect changes in oxygen saturation, thus providing an early warning of dangerous hypoxemia. [7, 8] The use of pulse oximetry for patient assessment and monitoring is well established in critical care, anesthesiology, and emergency departments. [7] In recent years, the availability of small, user-friendly, portable and affordable pulse oximeters, including those worn on the finger-tip has opened up the potential for use of this technique in an expanded variety of clinical settings, including primary care. [9] Determination of the necessary muscle stimulator electronic characteristics requires

understanding of the properties of nerves and muscles activation.

Three characteristics of electric impulses influence nerve fibers stimulation. These are [10] the value or amplitude of the pulse, the rate of change (or rise) of the pulse, the width or duration of the pulse. Muscle stimulators are widely used in sports training and for adult people whose muscles do not work properly or are going through some injury. The ability of electrical stimulation protocols to improve skeletal muscle performance in healthy and dysfunctional muscle is widely accepted and routinely demonstrated in research studies as well as in clinical practice.[11-17] Patients generally do not know the proper time period for which the stimulation should be given so that they do not over stimulate their muscles. With prolonged stimulation the muscles start to degenerate as the start losing the oxygen content in the muscle. With the help of the pulse oximeter in this device the patient can keep a check on his oxygen level during and after the stimulation. With this device people will be aware about the proper stimulation time period and what should be the approximate duration of time for stimulation to benefit the muscles. The pulse oximeter attached with the muscle stimulator will help in knowing the oxygen level in the patient. This oxygen level will help in improving the affect provided by the muscle stimulator and thus will be able to reduce the side effect of the continuous use of muscle stimulator. This device can be used in gyms and home for people with muscle injuries. In gyms people generally do weight trainings and put a lot of load on their muscles. With the overload which people apply on their muscles they eventually end up with over stretching of muscles and sometimes small injuries. People generally do not consult doctors for such small muscle injuries and end up using electronic muscle stimulators available in market. For faster recovery they use these stimulators continuously and hence get relief form pain. But they are unaware about the fact that such use of muscle stimulator without guidance can end up in destroying their muscles biological activity.

II. EXPERIMENTAL METHODOLOGY

2.1. Materials

A circuit which stimulates nerves of the part of your body exactly where electrodes are generally attached. It is useful to help remedy headache along with muscular discomfort and bring back frozen muscles that impair movement. Though it offers muscles stimulation and invigoration, it's mostly an aid in removing cellulites. The device comprises 2 units: muscular stimulator and also timer. This is an electronic muscle stimulator circuit that stimulates nerves of that part of your body where electrodes are attached. It is useful to relieve headache and muscle pain and revive frozen muscles

that impair movement. It's mainly muscle stimulation aid is removing cellulites and build up muscles. This is a small, portable set, designed for those aiming at look improvement. IC 7555 is wired as a stable multi vibrator to generate about 80Hz pulses. Using potentiometer VR1 you can control the intensity of current sensing at the electrodes. If you want to increase the intensity level, replace the 1.8kΩ resistor with 5.6kΩ or higher value up to 10kΩ. X1 is a small mains transformer with 220V primary to 12V, 100/150mA secondary. It must be reverse connected, i.e., connect the secondary winding to the collector of T2 and ground, and primary winding to the output electrodes. The output voltage is about 60V but the output current is so small that there is no threat of electric shock. C1 generates 150μSec. pulses at about 80 Hz frequencies. Q1 acts as a buffer and Q2 inverts the polarity of the pulses and drives the Transformer. The amplitude of the output pulses is set by P1. D2 protects Q2 against high voltage peaks generated by T1 inductance during switching. Electrodes are made of small, thin gauge metallic plates measuring about 2.5×2.5 cm² in size. Use flexible wires to solder electrodes and connect to the output of the device. Before attaching metal electrodes to the body, wipe with a damp cloth. After attaching the electrodes to the body (with the help of elastic bands on Velcro straps), flip switch S1 to activate the circuit and rotate the knob of intensity-control preset VR1 very slowly until you feel a slight tingling sensation. T1 is a small mains transformer 220 to 12V @ 100 or 150mA. It must be reverse connected i.e. the 12V secondary winding across Q2 Collector and negative ground, and the 220V primary winding to output electrodes. Output voltage is about 60V positive and 150V negative but output current is so small that there is no electric-shock danger.

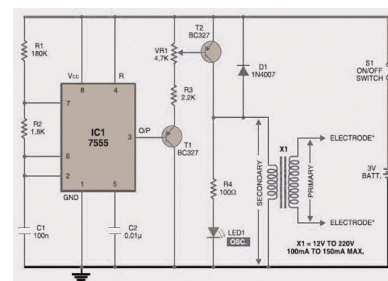

Fig. 1 shows the circuit of the muscle stimulator.

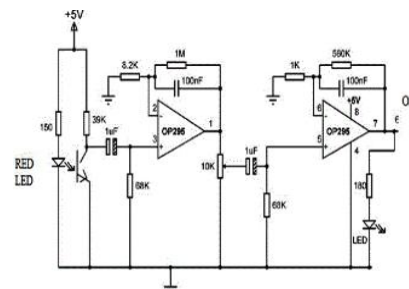

Fig 2 : Circuit diagram for red LED

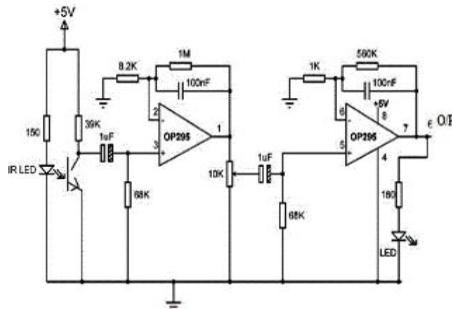

Fig 3: Circuit diagram for IR LED

Pulse oximetry uses the optical properties of blood to determine blood oxygen saturation. Our pulse oximeter will have two parts: a finger probe and the oximeter circuitry. It will contain two LEDs, one that works at a red wavelength and the other at a near infrared (NIR) wavelength. Also, in the probe will be a photo detector that will detect the light transmitted through the finger. A non-inverting op amp combined with a FET will be used to create a constant current source to drive the LEDs. Two 555 timer circuits will be used to control the timing of the pulsing of the LEDs. An n-channel enhancement-mode MOSFET connected across the each LED will be used to pulse the output from them. In the receiving end of the circuit is the photo detector. The photo detector used in pulse oximetry probes is a photodiode. The photodiode detects the light transmitted through the finger as current. An op-amp configured for current-to-voltage conversion will convert the photodiode-detected current to voltage. The timing circuits that were used to control the red and NIR LED drivers also are used to provide the control pulses for their corresponding sample-and hold circuits. A simple sample-and-hold circuit can be created from a FET switch, capacitor, and op amp. Once the signal goes through the sample-and-hold circuit, it is sent through a band pass filter to eliminate noise, then amplified and sent through an A/D converter and the microprocessor to be analyzed. A lookup table stored in the microprocessor will be used to calculate SpO2 values. This signal is also sent through a low pass filter to extract the d.c. value of the transmitted signal, which is then sent to an automatic gain control circuit. The gain control circuit adjusts the light intensity from the LEDs so that the d.c. level always remains at the same value, whatever the thickness of the patient's skin, tissue, etc. This circuit is implemented by feeding the d.c. signal to one input of a differential amplifier. The other input to the amplifier is a constant reference voltage. The output of the differential amplifier, the voltage difference between the two inputs, is used to generate the voltage that sets the value of the LED currents.

2.2. Methodology

This device is a combination of both pulse oximeter and electronic muscle stimulator. This device will help a patient with muscle injuries or any other muscle related problem to know about the proper time for which they should use muscle stimulator by letting them know the level of oxygen in their body before and after the stimulation. Before stimulation it is recommended that the patient checks his/ her oxygen level and after sometime stop the stimulation and check the level again. With the frequent check on the oxygen the patient will be able to understand the alteration in their oxygen level in the time period. By knowing the alteration in the level of oxygen one can predict the time period which will be suitable for stimulation. This understanding in patient will help in reducing the problems which can be caused due to the overuse of muscle stimulators. We are using our device on people who are regularly putting load on their muscles through different physical trainings as done in gyms. These people regular apply stress on their muscles and often end up with muscle injuries. They either use pain relief sprays or muscle stimulators for instant relief from the pain. But they are unaware about the fact that these muscle stimulators when used constantly for a longer period of time will result in reducing the biological property of their muscles. With the help of this device we were trying to know the variation in the oxygen level of different individuals.



Fig 4: Muscle Oximete

III. ANALYSIS & OBSERVATIONS

3.1. Analysis

For analysis we operated this device on 10 different individuals. These individuals were of the age 30 -35. We were trying to see that if we given stimulation for 15 minutes continuously then what will be the changes in the oxygen level of the body. Since oxygen is very important for the muscles, its degeneration can cause serious muscle problems. The individuals we tested upon are people who are involved in physical training. People use muscle stimulators to enhance the performance of their

muscles and thus start using these stimulators for a much longer period of time than necessary.

Analysis was done keeping the following parameters:

1. Age
2. Weight
3. Spo2 level before stimulation
4. Spo2 level after stimulation

NAME	AGE	WEIGHT	TIME OF STIMULATION (MINS)
JOSHI	30	72	15
SANJEEV	35	77	15
DANDAPANI	30	70	15
DIVAKAR	32	72	15
RANJEET	35	75	15
RAGHAV	30	75	15
NITIN	33	76	15
MANDEEP	30	70	15
MOHAN	35	77	15
DAYANAND	32	75	15

3.2. Result

NAME	AGE	WEIGHT	TIME OF STIMULATION (MINS)	SpO2 BEFORE	SpO2 AFTER
JOSHI	30	72	15	95	90
SANJEEV	35	77	15	96	92
DANDAPANI	30	70	15	95	89
DIVAKAR	32	72	15	95	91
RANJEET	35	75	15	96	96
RAGHAV	30	75	15	95	97
NITIN	33	76	15	97	95
MANDEEP	30	70	15	98	98
MOHAN	35	77	15	97	94
DAYANAND	32	75	15	98	95

With the help of this device we were able to observe that with the continuous use of muscle stimulator for 15mins there was a difference in the oxygen level of individuals. With this difference it is evident that

muscle stimulators overuse reduce the oxygen level in the body which eventually reduces the biological activity and hence the performance of the muscles.

IV. CONCLUSIONS

With a stimulation period of 15 mins over these individuals we came to know that there is a decrease of 5% in the oxygen level when stimulation is been provided for prolonged time. Hence we can conclude that our hypothesis that oxygen level decreases noticeably when stimulation through an electrical device is been given for a longer duration of time has been justified. With the help of this pulse oximeter circuit which is been attached to the muscle stimulator circuit we are able to know the oxygen saturation level in the patient body while stimulation is been provided and after the stimulation. With the help of this device the patient will be benefited as he will be able to know when to stop the stimulation and what should be the approximate time for the stimulator to work on his body muscles. Hence we can conclude that our hypothesis that continuous use of muscle stimulators decrease the efficiency of the muscles by reducing the oxygen content is been justified with the device and the analysis done.

This device can be used in gyms and home for people with muscle injuries. In gyms people generally do weight trainings and put a lot of load on their muscles. With the overload which people apply on their muscles they eventually end up with over stretching of muscles and sometimes small injuries. People generally do not consult doctors for such small muscle injuries and end up using electronic muscle stimulators available in market. For faster recovery they use these stimulators continuously and hence get relief from pain. But they are unaware about the fact that such use of muscle stimulator without guidance can end up in destroying their muscles biological activity. With the help of our device people undergoing problems with their muscles such as muscle spasm or people undergoing weight training who frequently require such stimulators will be benefited. This device will help such individuals to know the time duration for which they should use this stimulation. It will help in knowing them that for how much duration the stimulation will be beneficial and after what duration it will harm their muscles.

V. REFERENCES

- [1]. AJ. Bergquist, JM. Clair, O. Lagerquist, CS. Mang, Y. Okuma, DF. Collins, "Neuromuscular electrical stimulation: implications of the electrically-evoked sensory volley," Eur. J. Appl. Physiol., doi:10.1007/s00421-011-2087-9. 2011.
- [2]. GY. Millet, V. Martin, A. Martin, S. Verge`s, "Electrical stimulation for testing neuromuscular function: from sport to

- pathology,” *Eur. J. Appl. Physiol.*, doi:10.1007/s00421-011-1996-y. 2011.
- [3]. T. Hortobagyi, NA. Maffiuletti, “Neural adaptations to electrical stimulation strength training,” *Eur. J. Appl. Physiol.*, doi: 10.1007/s00421-011-2012-2. 2011.
- [4]. CM. Gregory, CS. Bickel, “Recruitment patterns in human skeletal muscle during electrical stimulation,” *Phys. J. Ther.*, vol. 85, pp. 358364, 2005.
- [5]. R. Merletti, L.R. Lo Conte, C. Orizio, “Indices of muscle fatigue,” *J. Electromyogr. Kinesiol.*, vol.1, pp. 20-33. 1991.
- [6]. Neuman MR. 1987. Pulse oximetry: physical principles, technical realization and present limitations. *Adv Exp Med Biol* 220:135-44.
- [7]. National Health Service (UK) Center for Evidence-based Purchasing. 2009. Project initiation document: Pulse oximeters.
- [8]. Holmes S, and SJ Peffer. 2009. PCRS-UK Opinion Sheet No. 28: Pulse Oximetry in Primary Care. www.pcrs-uk.org.
- [9]. Schermer T, et al. 2009. Pulse oximetry in family practice: indications and clinical observations in patients with COPD. *Fam Pract* 26(6):524-31.
- [10]. Ward, A.R.: *Biophysical Bases of Electrotherapy*, Butterworth-Heinemann, Oxford, 2006.
- [11]. Stevenson SW, Dudley GA. Dietary creatine supplementation and muscular adaptation to resistive overload. *Med Sci Sports Exerc.* 2001;33: 1304–1310.
- [12]. Stein RB, Chong SL, James KB, et al. Electrical stimulation for therapy and mobility after spinal cord injury. *Prog Brain Res.* 2002;137: 27–34.
- [13]. Belanger M, Stein RB, Wheeler GD, et al. Electrical stimulation: can it increase muscle strength and reverse osteopenia in spinal cord injured individuals? *Arch Phys Med Rehabil.* 2000;81:1090–1098.
- [14]. Dudley GA, Castro MJ, Rogers S, Apple DF Jr. A simple means of increasing muscle size after spinal cord injury: a pilot study. *Eur J Appl Physiol Occup Physiol.* 1999;80:394–396.
- [15]. Ruther CL, Golden CL, Harris RT, Dudley GA. Hypertrophy, resistance training, and the nature of skeletal muscle activation. *J Strength Cond Res.* 1995;9:155–159.
- [16]. Stevens JE, Mizner RL, Snyder-Mackler L. Neuromuscular electrical stimulation for quadriceps muscle strengthening after bilateral total knee arthroplasty: a case series. *J Orthop Sports Phys Ther.* 2004;34:21–29.
- [17]. Lewek M, Stevens J, Snyder-Mackler L. The use of electrical stimulation to increase quadriceps femoris muscle force in an elderly patient following a total knee arthroplasty. *Phys Ther.* 2001;81:1565–1571.