

# Sensible Expansion Of Intellectual Disposal Of Garbage System By Using IOT

A SREEJA

M.Tech Student, Department Of ECE, Nishitha  
College of Engineering and Technology,  
Hyderabad, T.S, India.

CH SREEDHAR

Assistant Professor, Department Of ECE, Nishitha  
College of Engineering and Technology,  
Hyderabad, T.S, India.

**Abstract:** Many times, in our town we see that the rubbish boxes or dustbins located at public places are overloaded. It creates unhygienic conditions for human beings similarly to ugliness to that vicinity leaving unsightly smell. To keep away from all such conditions we're going to put into effect a venture referred to as IoT Based Intelligent disposal of rubbish. In this undertaking dustbins are interfaced with microcontroller based machine having Ultrasonic sensor and IR sensor at the side of big tool displaying contemporary-day fame of garbage, on cellular net browser with html page thru Wi-Fi. This tool additionally includes fuel sensor within it to avoid leakage of poisonous gases from the field. Hence the popularity might be updated directly to the html page. And the statistics detected can be dynamically despatched to all the stakeholders concerned within the system and it leads to the optimized series routes of rubbish bin. Here the admirable function present is that we deliberate to provide unfastened Wi-Fi for a person who is dumping the waste into the rubbish bin through shifting Wi-Fi code. It is probably used by a person in the precise distance from the garbage bin. Major part of our task relies upon the going for walks of the Wi-Fi module, essential for its implementation. The fundamental goal of this undertaking is to reduce human sources and efforts together with the enhancement of a smart metropolis imaginative and prescient.

**Keywords:** WIFI Module; Garbage Bin; Gas Sensor; Smart City; IR Sensor;

## I. INTRODUCTION

The Internet of Things (IoT) is a concept in which surrounding objects are connected via wired and Wi-Fi networks without person intervention. In the field of Internet of Things, the devices talk and change statistics to offer superior sensible services for clients. Owing to the recent advances in cell devices ready with numerous sensors and verbal exchange modules, together with verbal exchange community generation which includes Wi-Fi and LTE, the Internet of Things has won giant educational interests. In present-day times, due to rapid populace increase, disorganization of city governments, a lack of public recognition and restrained investment for programs waste manage, rubbish disposal has come to be a big motive of state of affairs in the global. A voluminous amount of waste generated is disposed of with the resource of means which has an adverse impact on the surroundings. The Central Public Health and Environment Engineering Organization (CPHEEO) have expected that waste generation in India as an awful lot as 1.3 kilos in line with the person in keeping with day [2]. This determines is distinctly low, as compared to the 4.6 kilos of waste generated consistent with man or woman regular with day inside the United State (U.S.). But the U.S. Populace became near 307 million in July 2009, whereas India's population became 1.2 billion. These data recommend that India can be generating as an entire lot as 27 million more masses of waste than the U.S. In line with three

hundred and sixty-five days [6]. The not unusual method of disposal of waste or garbage is unplanned and out of manipulating overtly being dumped at the roads or overflowing within the rubbish cans and so forth. This exercise is unhygienic and dangerous to human, plant, and animal lifestyles. This unhygienic approach of dumping garbage can generate liquid leach ate which in turn may additionally contaminate ground and groundwater; for that reason harbouring ailment vectors spreading risky ailments and degrading aesthetic price of the impartial environment. The concurrent results of a brief growing use, its large, dense populace, and pressing call for urban environmental protection is developing a difficult framework for waste management.

## II. PRIVIOUS STUDY

This is not a unique concept, for the implementation of a clever rubbish bin; the idea has existed for many years After the IoT discipline locating its grip in our lives. This is, however, specific plan for designing clever garbage bin with the ultrasonic sensor, IR sensor, gas sensor and Wi-Fi module for transmission of records. A State of the Art evaluation on the Internet of Things through P. Suresh, Vijay. Daniel, R.H. Aswathy, Dr. V. Parthasarathy. It gave the concept of IoT state of affairs and addition facts approximately IoT. The proper smart environment and numerous programs. Internet of Things: Challenges and nation-of-the art solutions in Internet-scale Sensor Information

Management and Mobile analytics by means of way of Arcady Zaslavsky, Dimitrios Georgakopoulos. This paper gave us the statistics approximately cell evaluation and sensor data manipulate in an effort to assist in information segregation of several dustbins. Top-ok Query based totally dynamic scheduling for IoT-enabled small city waste series by using Theodoros Anagnostopoulos, Arkady Zaslavsky, Alexey Medvedev, and Sergei Khoruzhnicov. It gave us the idea of dynamic scheduling required for the cleansing of the dustbin and the Top-k query led us to priority primarily based definitely cleansing of dustbins. City Garbage series indicator using RF (Zigbee) and GSM era. This paper gave the information for the module required for the transmission of the information to the receiver side and moreover, the number one channel follows of the assignment. Initially, we used GSM generation for our venture however in a while decided to us Wi-Fi module for the benefit of information transmission.

### III. METHODOLOGY

Considering the want of contemporary-day generation the smart garbage bin can highly-priced but thinking about the amount of dustbin wanted in India, steeply-priced garbage bin won't be a previous check this is why we have decided to use based totally sensors to lessen its charge and additionally make it inexperienced in packages. The sensors used may be very less expensive in fee and the facts amassed also may be despatched to all the stakeholders of the device. The purpose of our proposed device is to make our environment hygienic and easy via encouraging the people to place the garbage in the containers as well as lessen the intake of the fuel used for transportation of trash. The clever rubbish bin works on the rising futuristic generation known as the Internet of Things (IoT). In the proposed device the precept of the internet of factors could be used to link each rubbish bin to a nearby server in a society. The human beings will need to position their rubbish thru the flap door supplied on the front of the garbage bin. The lid may be locked and the sensor circuit might be resting below the lid, will be properly covered with water and different risks. When a person dumps trash into the rubbish bin the distance among the rubbish pile and the pinnacle lid has calculated the use of an ultrasonic distance sensor and the information is transmitted to the server via a microcontroller which is likewise constant underneath the lid of the rubbish bin. If the garbage bin is 85% complete then a caution is probably sent to the server and the officials are notified of the popularity and sent to that specific rubbish bin for collection. Hence the garbage isn't piled up and the cars are assigned as in line with

the range of pickup places and amount, therefore gas is also stored.

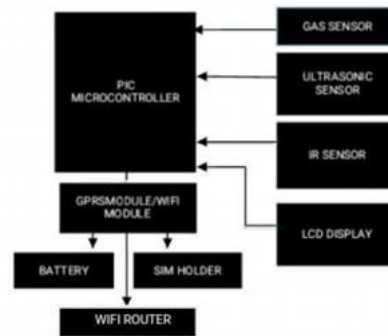

**Fig.3.1. Block diagram.**

### IV. SIMULATION RESULTS

The essential objective of our project includes making use of IoT technology (electronics and applications) to the modern-day urban waste control situation and allows a two manner conversation a number of the infrastructures deployed within the town and the operators/directors. A centralized gadget for real-time monitoring is our purpose to accumulate. In this way, both the municipal and citizens gain from an optimized machine which leads to foremost fee savings and much fewer city pollutants.



**Fig.4.1. Hardware kit image.**

### V. CONCLUSION

This idea is the implementation of wise garbage disposal device the usage of IR and ultrasonic sensor, in mixture with PIC microcontroller and Wi-Fi module. This implementation offers a cleaning of the waste area quickly when the trash can stage reap its most threshold price. If the rubbish can isn't always wiped easy amongst the perfect levels of time given, then the facts accumulated is sent to the stakeholders who can take suitable motion in opposition to the concerned person. This shrewd smart disposal of waste is used to keep the music of the fake evaluations and to decrease the price of corruption in the management device. It gives the optimized way of rubbish series and consequently decreases the heavy routes of rubbish series stated in the conventional way. It helps to hold neatness inside the surroundings to make our society sickness unfastened with a smooth surrounding.

## VI. REFERENCES

- [1] Ikuo Ihara; Nagaoka University of Technology; Ultrasonic Sensing: Fundamentals and Its Applications to Nondestructive Evaluation.
- [2] Arduino, "Available at <http://www.Arduino.Cc>," 2010.
- [3] M. Batty, "Smart Cities, Big Data," Environment and Planning B: Planning and Design 2012, vol. 39, pp. 191–ninety three.
- [4] Xu Li, Student Member, IEEE, Performance Evaluation of Vehicle-Based Mobile Sensor Networks for Traffic Monitoring.
- [5] Yusuf Abdullahi Badamasi, The Working Principle Of An Arduino, Electronics, Computer and Computation (ICECCO), 2014 eleventh International Conference on 29 Sept.-1 Oct. 2014.
- [6] Pedro Reis , Rui Pitarma, Celistino Goncalves, Intelligent System for Valorizing Solid Urban Waste, Filipe Caetano Faculty of Engineering UBI University of Beira Interior Covilha, Portugal, 2015.
- [7] Adnan Aijaz, Member, IEEE; Cognitive Machine-to system Communications for Internet-of-Things: A Protocol Stack Perspective.